

1	VG	CAP+
2	VSS	0V
3	VDD	3.3V
4	SCL	H/L
5	SDA	H/L
6	AO	H/L
7	REST	L
8	CS	L

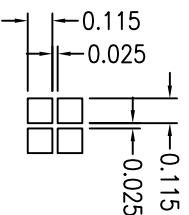

SCALE 10:1

NOTES:

1. Model: (型号) : DJM12864G11
2. Display Mode (显示模式) : FSTN (正性) (半透)
3. Display Direction (视角方向) : 12 O'Clock
4. Driving Method (驱动方式) : 1/64Duty (占空比) : 1/9Bias (偏压比)
5. Operating Voltage (工作电压) : 3.3V
6. Operating Temp (工作温度) : -20° c--+70° c
7. Storage Temp (储存温度) : -30° c--+80° c
8. Display type(显示类型) : STN POSITIVE
9. Connector (连接方式) : 金属PIN针
10. Connector (连接方式) : 金属PIN针

REV

深圳市大帝金茂实业有限公司

DRAWN BY: PQH  
CHECKED BY: LZH  
LCD NO: DJM12864G11

APPROVED BY: UNIT: MM

DATE: 2015-08-05

1 OF 4

此页图面仅供参考走线

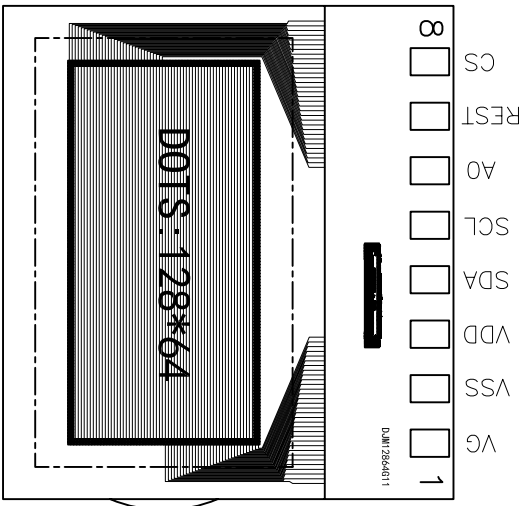

COMMON

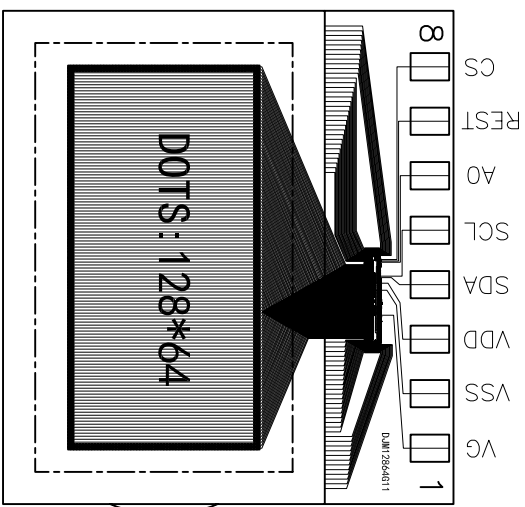



SEGMENT

REV

深圳市大帝金茂实业有限公司

DRAWN BY:	PQH	LCD NO: DJM12864G11
CHECKED BY:	LZH	

APPROVED BY:		 	UNIT:
DATE:	2015-08-05		2 OF 4

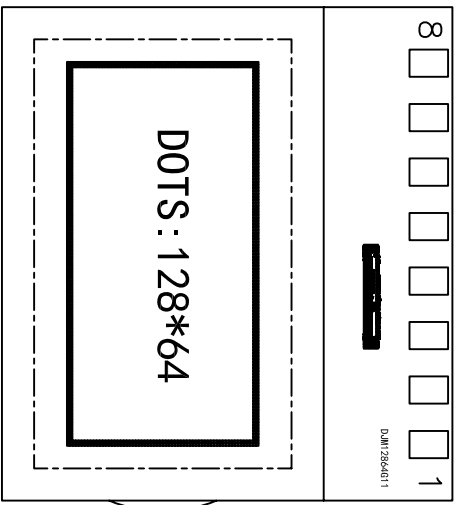

LCD 显示效果图

LCD DISPLAY EFFECT

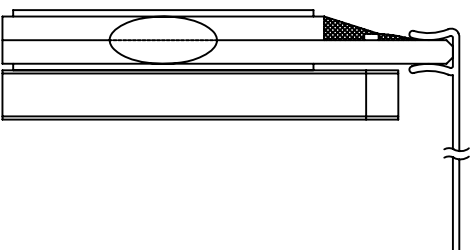

LCD+LED贴合效果

REV

深圳市大帝金茂实业有限公司

DRAWN BY:	PQH	LCD NO: DJM12864G11
CHECKED BY:	LZH	
APPROVED BY:		
DATE:	2015-08-05	3 OF 4

LED

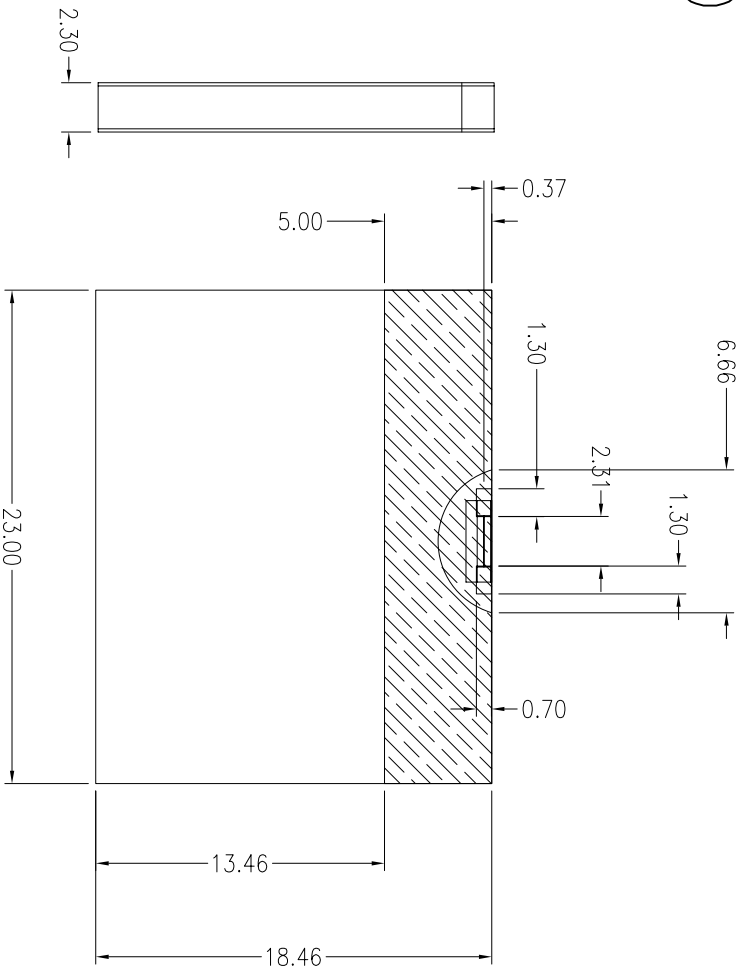

3、Package Outline Dimension:

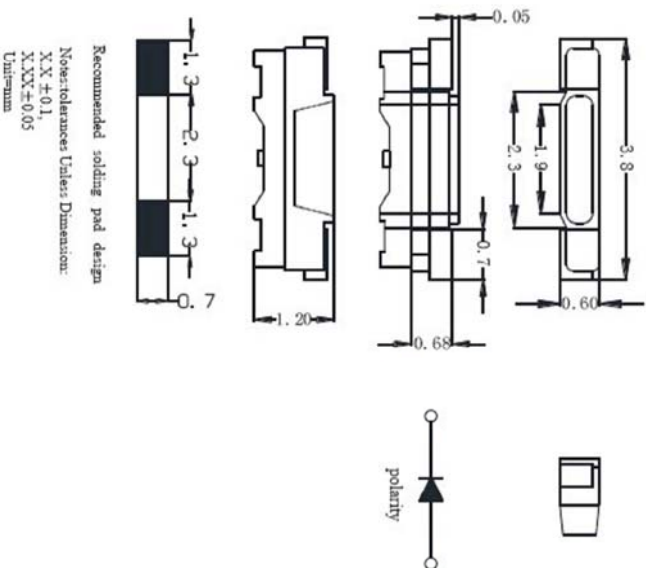

LED型号: 020

LED焊接在客户主板上，由客户自己贴片，  
 请客户注意在PCB上设计焊接LED的焊盘位置以及焊盘大小  
 我公司提供导光板和LED灯芯  
 灯芯：蓝色

REV

深圳市大帝金茂实业有限公司

DRAWN BY: PQH LCD NO: DJM12864G11

CHECKED BY: LZH

APPROVED BY:

DATE:

2015-08-05

4 OF 4

MM