

1. DIMENSION OUTLINE

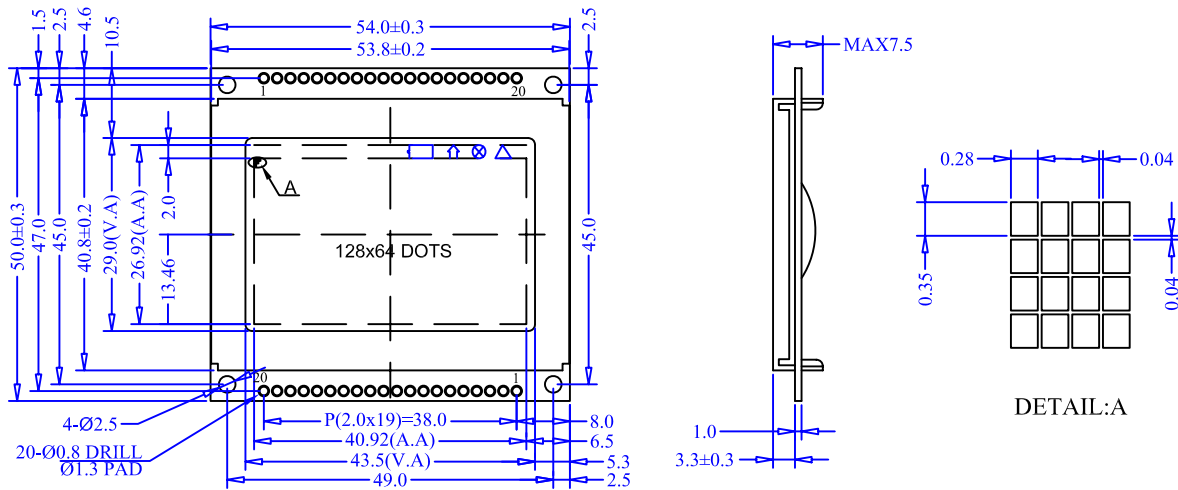

2. MECHANICAL SPECIFICATIONS

ITEM	SPECIFICATIONS	ITEM	REMARK
Module Size(L×W×H)	54.0×50.0×7.5	mm	Reference Dimensional Outline
View Area(W×H)	43.5×29.0	mm	
Effective V/Area	40.92×26.92	mm	
Number of Characters	128×64	-	
Dot Pitch(W×H)	0.32×0.39	mm	
Dot Size(W×H)	0.28×0.35	mm	
Weight (Reflective/Led)	-	g	

3. ABSOLUTE MAXIMUM RATINGS

ITEM	SYMBOL	CONDITION	STANDARD	
			MIN	MAX
Logic Voltage	V _{DD}	Ta=25°C	-0.3V	7V
LCD Voltage	V _{LCD}		-0.3V	17.5V
Input Voltage	V _I		-0.3V	V _{DD} +0.3V
Operation Temperature	T _{OP}	—	-20°C	70°C
Storage Temperature	T _{st}	—	-30°C	80°C

4. BLOCK DIAGRAMMECHANICAL

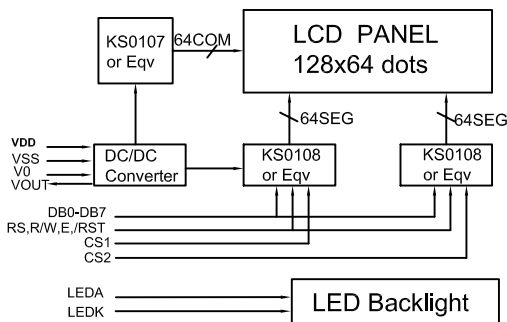

5. LED BACKLIGHT SPECIFICATIONS

ITEM	SYMBOL	TYPE	MAX	UNIT
Ta=25°C				
Input Voltage	V _{EL}	100	—	V
Input Frequency	f _{el}	400	—	Hz
Forward Current	I _{EL}	15	—	mA

6. INTERFACE PIN CONNECTIONS

ITEM	SYMBOL	LEVEL	FUNCTIONS
1	VSS	0V	Power Ground
2	VDD	+5V	Power supply for logic
3	V0	—	Contrast adjust
4	RS	H/L	H:data L:command
5	R/W	H/L	H:read L:write
6	E	H,H→L	Enable signal
7-14	DB0-DB7	H/L	Data Bus
15	CS1	H	Chip selection IC1
16	CS2	H	Chip selection IC2
17	/RST	L	Reset signal
18	VOUT	—	Output voltage for lcd driving
19	LEDA	H	Power supply for LED backlight
20	LEDK	0V	

7. ELECTRICAL CHARACTERISTICS

ITEM	SYMBOL	MIN	TYPE	MAX	UNIT
Ta=25°C					
Logic Power	V _{DD}	4.5	5	5.5	V
Input High Voltage	V _{IH}	0.8V _{DD}	—	V _{DD}	V
Input Low Voltage	V _{IL}	VSS	—	0.8	V
Output High Voltage	V _{OH}	2.4	—	—	V
Output Low Voltage	V _{OL}	0	—	0.4	V
Logic Current	I _{DD}	—	6	8	mA
Operation Voltage For LCD	V _{DD} -V ₀	—	8	—	V